

## WS Series Electric Pallet Truck With Lithium Battery Specification

		HANGCHA GROUP CO.,LTD.						
		Model	CBD18-WS-SE	CBD18-WS-SEQ	CBD15-WS	CBD18-WS		
Characteristics	1.1	Capacity	kg	1800	1800	1500	1800	
	1.2	Load center	mm	600	600	600	600	
	1.3	Standard overall fork width	mm	550/685	550/685	550/685	550/685	
	1.4	Fork length	mm	1150/1220	1150/1220	1150/1220	1150/1220	
	1.5	Overall length	mm	1552/1622	1552/1622	1552/1622	1552/1622	
	1.6	Overall height (with tiller)	mm	1300	1300	1300	1300	
	1.7	Rear body width	mm	550/685	550/685	550/685	550/685	
	1.8	Minimum turning radius	mm	1353/1426	1353/1426	1353/1426	1353/1426	
Performance	2.1	Max.Traveling speed	laden	km/h	3.5	3.5	4	4
			unladen	km/h	5	5	5	5
	2.2	Gradeability	laden	%	5	5	6	6
			unladen	%	20	20	20	20
	2.3	Traveling	kw	DC 0.75 Brushless	DC 0.75 Brushless	DC 0.75 Brushless	DC 1.0 Brushless	
2.4	Lifting	kw	Hydraulic	QUICK LIFT	DC 0.5	DC 0.5		
Battery	4.1	Voltage	v	48	48	48	48	
	4.2	Capacity/type	Ah	10 Ah Lithium	10 Ah Lithium	10 Ah Lithium	10 Ah Lithium	
Brake Type	5.1	Travel brake		Regenerate	Regenerate	Regenerate	Regenerate	
	5.2	Brake		Electromagnetic	Electromagnetic	Electromagnetic	Electromagnetic	
Controller	6.1	Controller		STAXB1501	STAXB1501	STAXB1501	STAXB1501	

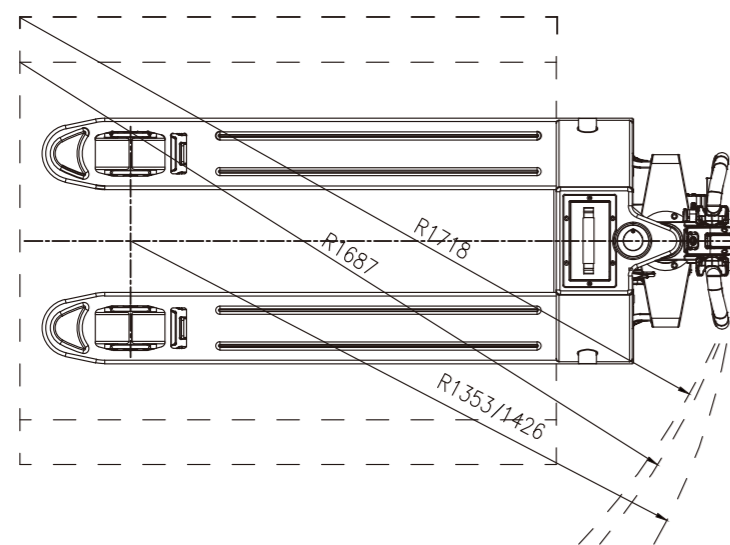
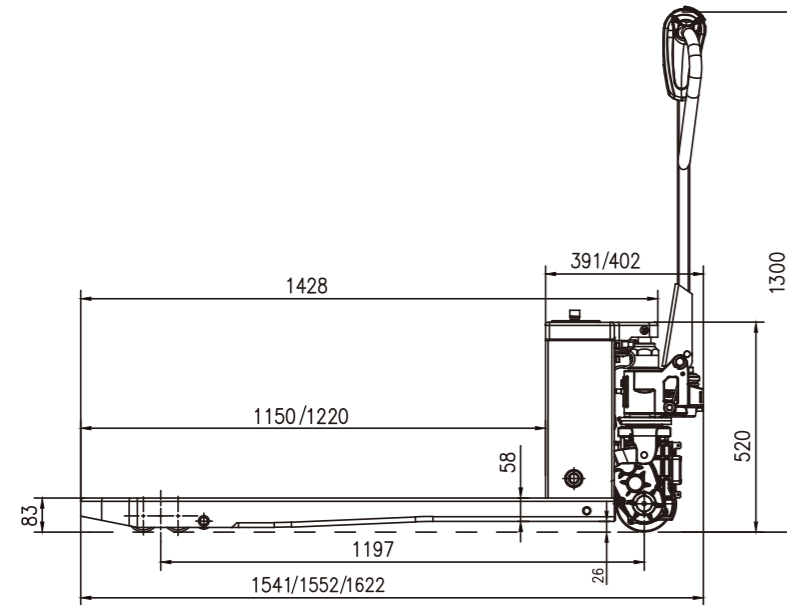

**HANGCHA**

**ZHEJIANG HANGCHA IMP. & EXP. CO., LTD.**

**Factory site:** 666 Xiangfu Road,  
Hangzhou, Zhejiang, China (311305)

Tel: +86-571-88926735 88926755  
Fax: +86-571-88926789 88132890

sales@hcforklift.com  
www.hcforklift.com



Follow us on  
Facebook



Follow us on  
YouTube



Follow us on  
WeChat



Download "Hangcha  
Forklift" App



ISO14001  
ISO14001:2015



ISO9001  
ISO9001:2015



HANGCHA trucks conform  
to the European Safety  
Requirements.

HANGCHA GROUP CO., LTD. reserves the right to make any changes without notice concerning colors, equipment, or specifications detailed in this brochure, or to discontinue individual models. The colors of trucks, delivered may differ slightly from those in brochures.



## WS Series Electric Pallet Truck With Lithium Battery

with capacities of 1,500/1,800kg

*The World of Hangcha*  
SINCE 1956



**HANGCHA**

# PERFORMANCE

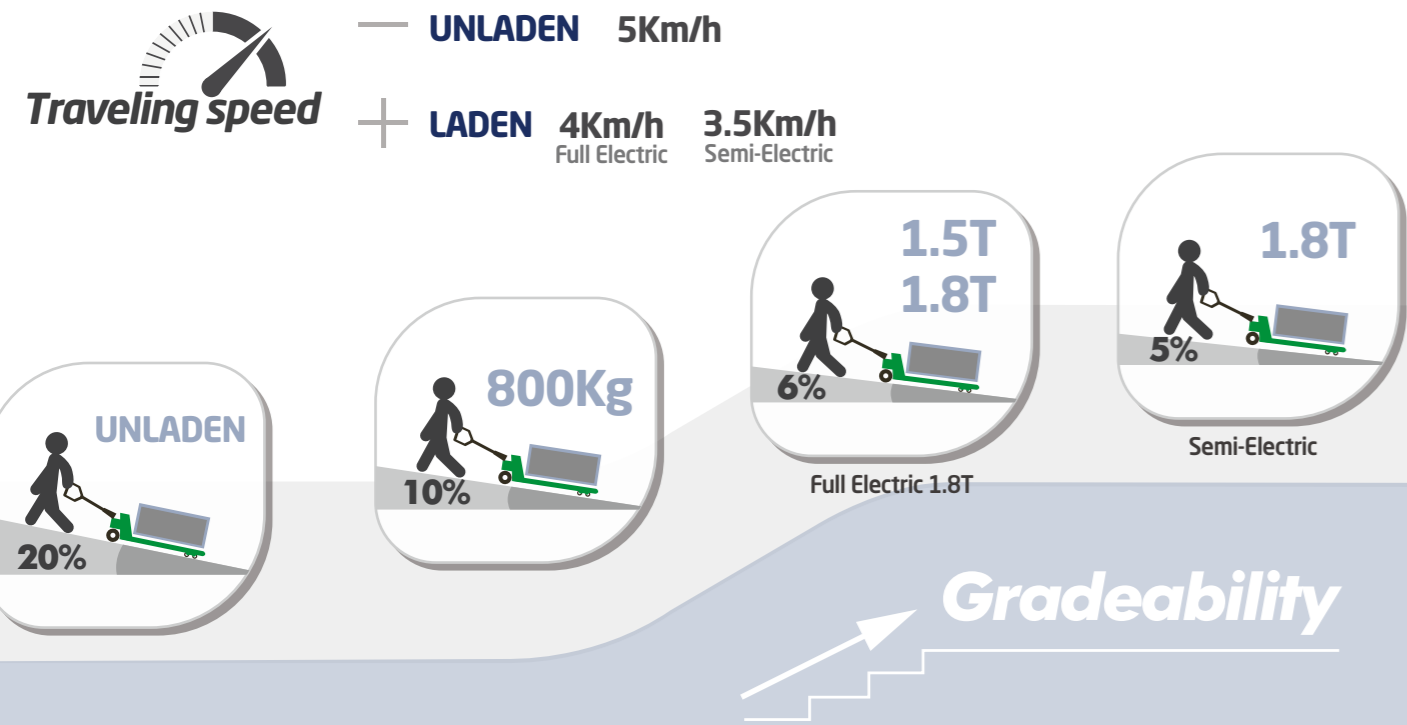

# SMART FUNCTION

### SMART FUNCTION 01

**Turtle Speed**  
Horn Remains Pressed & Forward 2 times

### SMART FUNCTION 02

**Up-Right Drive**  
Reverse Button & Forward Throttle Remain Pressed, Power On

### SMART FUNCTION 03

**Engineering Mode (Brake Release)**  
Horn Remains Pressed, Power On

**⚠ In up-right drive mode, vehicle will move when handle is operated at any position. Please avoid misoperation.**

**⚠ Brake release mode is only for emergencies, not allowed for vehicle with normal conditions.**

# CHARACTERISTICS

- Horn
- Emergency reverse button
- Forward/reverse butterfly switch
- Lifting / Lowering
- LCD Screen
  - Battery indicator with hour meter
  - Error code display
  - Recharge Alert

**Multi-function Handle (Full Electric)**

**Multi-function Ergonomic Handle (Semi-electric)**

# OPTIONS

- Single PU wheel
- Double PU wheel
- Protection cover
- Manual: Lifting/Lowering(Quick Lift)
- Fast Charger 2hrs

**BUILT TO WORK 24 HOURS**

**SMART SIZE ALMOST SAME**

**LIGHT WEIGHT**  
ELECTRIC PALLET TRUCK ONLY 125kgs vs HAND PALLET TRUCK 80 kgs

**EFFICIENCY**  
3 Times Higher Than Manual Pallet Truck

**EASY MAINTENANCE**

**LIFETIME**  
3 Times Longer Than Manual Pallet Truck

**PAY A LITTLE MORE SAVE MUCH MORE**

# MAINTENANCE SO EASY

- 5 YEAR WARRANTY CHASSIS**
- Brushless drive motor, maintenance free**
- Lithium-ion Lithium battery maintenance free**
- Recharge Alert**
- Error code display**
- 6s Replace Battery**
- 60s Replace Drive Wheel**

**Integral Forks: Ideal design for closed pallet(single load wheel)**

**Manual: Lifting/Lowering**

**Electric Lifting/Lowering**

**Lithium battery pack**