



**HC FORKLIFT AMERICA CORPORATION**

**Company address:**  
10405-A Granite Street Charlotte,  
NC 28273

Toll Free: 888-652-8395  
Phone: 980-888-8335  
Fax: 980-888-8336

america@hcforklift.com  
www.hcforkliftamerica.com



Follow us on  
Facebook



Follow us on  
YouTube



Follow us on  
WeChat



Download "Hangcha  
Forklift" App



ISO14001  
ISO14001:2015



ISO9001  
ISO9001:2015

2020 VERSION 1 / COPYRIGHT 2020 / 06

HANGCHA GROUP CO., LTD. reserves the right to make any changes without notice concerning colors, equipment, or specifications detailed in this brochure, or to discontinue individual models. The colors of trucks, delivered may differ slightly from those in brochures.



## A Series Walkie Pallet Jack

with capacities of 4,500lbs

*The World of Hangcha*  
SINCE 1956



# SMOOTHER TOUGHER MANEUVERABLE

A series walking pallet truck is newly developed logistics handling equipment developed by Hangcha for the North American market. The AC drive control technology provides advanced performance, comfortable operation, safe and reliable, low maintenance costs. It can be use for loading and unloading in warehouses, supermarkets and workshops.



## Appearance

- / A series pallet truck applied professional industrial design, stream lines, and compact, and fully ergonomic consideration, in line with the latest design trends.
- / Applied steel stamping and injection molding processes for front and back guard, which is robust, durable, and also environmental compliance.

## Performance

- / AC travelling motor applied to provide excellent acceleration, good gradeability, low heat, no carbon brush and maintenance free.
- / The latest CURTIS AC control system provides accurate and stable control to work more efficient.
- / The applied CAN-BUS structure can offer more reliable and faster command access.
- / Regenerative brake and slope anti-slide function are offered by this truck.

## Comfort

- / Turtle speed function can keep the slow move when the tiller is vertical direction, the truck can stack goods even in narrow space.
- / Optimized design structure to offer a good visibility and easy entrance of the pallet.
- / The compact body and big rounded design provide an ideal operation in limited space, and the wedge designed chassis greatly increases the passing ability.

## Safety

- / The power plug is fixed on the truck body to avoid damage from battery installment.
- / The applied slope anti-slip function ensures the safety of the operation.
- / The emergency button on the tiller head can effectively avoid the harm to the driver.
- / Lifting limitation switch to offer protection to the loads from damaging.



Simple and beautiful tiller designed to operate all functions easily even by one hand. Displayed turtle speed function applied to move slowly and helps to stack goods in narrow spaces



Built-in charger and maintenance free battery



Punch-formed forks to provide more strength and tip guide to provide higher efficient operation



The battery compartment is sized to fit either a 12-85-5 industrial battery in its 7.8 inch compartment for heavier throughput applications



Greater clearance over docks, lift gates and curbs means less wear and tear to carriage and components





## Standard features

- / 24 volt electrical system
- / CAN BUS communication
- / Curtis AC Controller
- / 7.8" Battery Compartment
- / PU drive tire
- / Maintenance-Free battery 150Ah
- / Built-in charger
- / SB-175 battery connector (red)
- / Battery disconnect handle
- / Key switch
- / Multi-function meter
- / Electric horn
- / Upright-tiller creep speed running
- / PU load wheel
- / Single load wheel
- / Balance leg

## Reliability

- / High strength steel frame structure chassis provide larger residual load capacity and longer working life.
- / Water-proof plugs and connectors applied to provide a reliable protection to electric system.
- / The limit switch of lifting motor eliminates overflow of the hydraulic power unit, which is more energy efficient, and can protect the motor of power unit.
- / Top quality hydraulic power unit applied to provide low noise, low vibration, smooth lifting and landing reliable operation.
- / The power plug (Andersen) is fixed on the truck body to avoid damage from battery installment.

## Maintenance

- / AC motor with no cabin brush, don't need maintenance, lower cost.
- / Integrated battery indicator, hour meter and self-diagnostic instrument are all easy for maintenance.
- / Rear cover can be completely open, operator can see all the components, so the maintenance is very convenient.
- / All shafts installed lubricated shaft sleeve and oil cup, provide convenient maintenance and long service life.



## Optional equipment

- / Maintenance-Free battery 225Ah
- / Industrial battery 240Ah
- / Load Backrest
- / PIN code access
- / Rubber drive tire
- / Balance wheels



# MORE POWER TO MOVE





# A Series Walkie Pallet Jack Specification

Distinguishing mark	1.1	Manufacturer	HANGCHA GROUP CO.,LTD.	
		HCFA Model	WP20	
	1.2	Manufacturer's type designation	CB020-AC1-NA	
	1.4	Operator type: hand, pedestrian, standing, seated, order-picker	Walkie	
	1.5	Rated capacity/rated load	Q (kg/lb)	2000/4500
	1.6	Load centre distance	c (mm/in)	600/24
	1.8	Load distance, centre of drive axle to fork	x (mm/in)	1000/39
1.9	Wheelbase	y (mm/in)	1424/56	
Weight	2.1	Service Weight Without Battery	kg/lb	360/795
Tyres, chassis	3.1	Tyres: solid rubber, superelastic, pneumatic, polyurethane	PU	
	3.2	Tyre size, front	mm/in	Φ230×75/Φ9×3
	3.3	Tyre size, rear	mm/in	Φ82.5×114/Φ3.25×4.5
	3.4	Additional wheel (dimensions)	mm/in	/
	3.5	Wheels, number front / rear (x = driven wheels)	1x+/2	
	3.6	Tread, front	b <sub>0</sub> (mm/in)	/
	3.7	Tread, rear	b <sub>1</sub> (mm/in)	510/20
Dimensions	4.4	Lift	h <sub>3</sub> (mm/in)	140/5.5
	4.15	Fork height, lowered	h <sub>3</sub> (mm/in)	85/3.35
	4.19	Overall length	l <sub>1</sub> (mm/in)	1770/70
	4.20	Length to face of forks	l <sub>2</sub> (mm/in)	620/24.4
	4.21	Overall width	b <sub>1</sub> (mm/in)	710/28
	4.22	Fork dimensions	s/e/l (mm/in)	60/170/1150(2.36/6.7/45)
	4.25	Distance between fork-arms	b <sub>s</sub> (mm/in)	680/27
	4.32	Ground clearance, centre of wheelbase	m <sub>2</sub> (mm/in)	23/0.9
	4.35	Turning radius	Wa (mm/in)	1530/60 <sup>1)</sup>
Performance data	5.1	Travel speed, laden/unladen	kph(mph)	6/6(3.7/3.7)
	5.2	Lift speed, laden/unladen	m/s(ft/min)	0.045/0.06(9/12)
	5.3	Lowering speed, laden/unladen	m/s(ft/min)	0.05/0.04(10/8)
	5.8	Max Gradeability, laden/unladen	%	10/16
Electric-engine	6.1	Drive motor rating S2 60 min	kW/hp	1.3/1.74
	6.2	Lift motor rating at S3 10%	kW/hp	1.2/1.6
	6.4	Battery voltage, rated capacity	V/Ah	24/150
	8.1	Type of drive control	AC	
	9.1	Manufacturer	Curtis	

Note: 1). When fork lowered, +90mm/3.5in

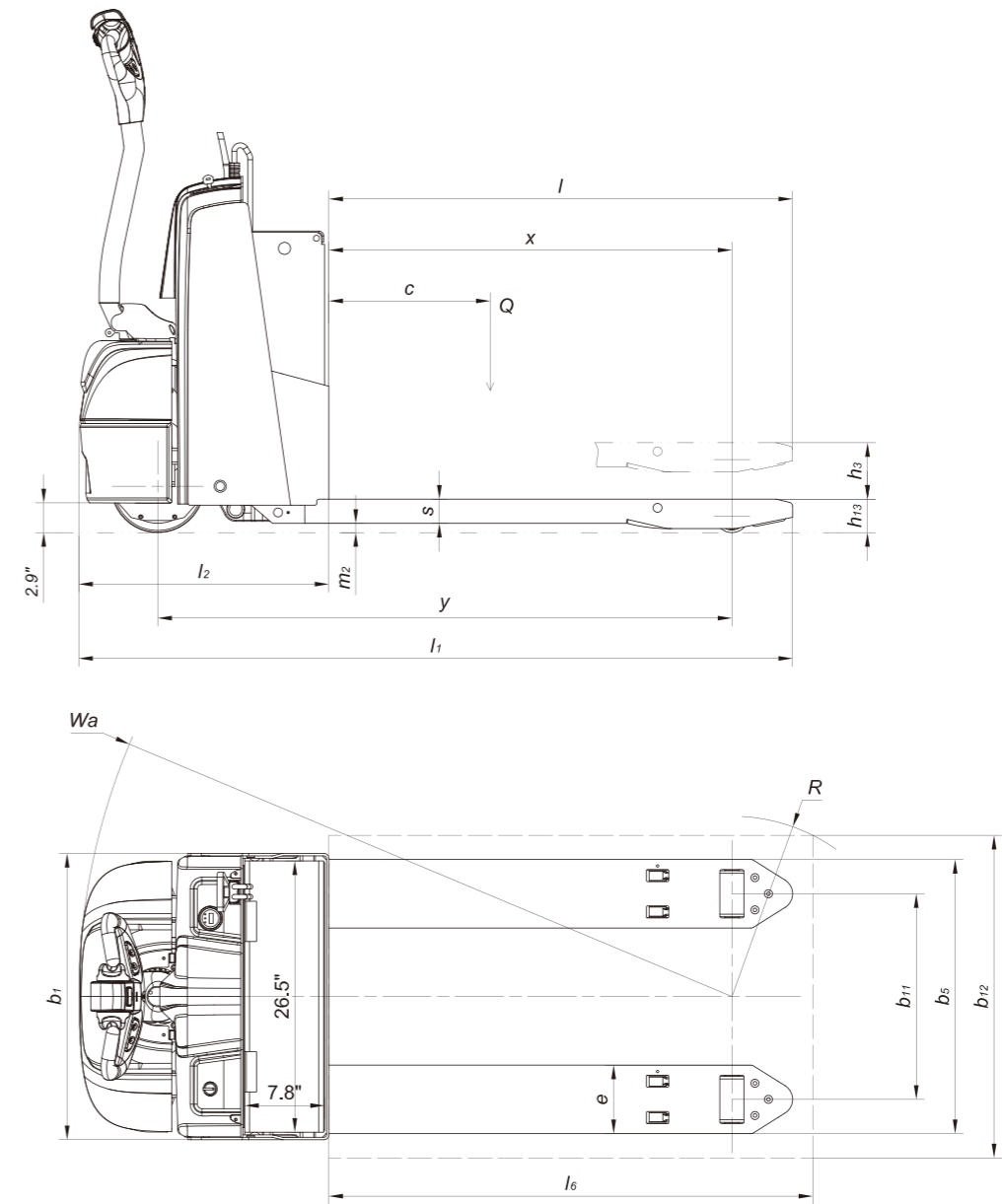

## Aisle Guide

### Aisle requirement-right angle stack ①

Fork length (actual)	in(mm)	29.5(750)	33.5(850)	39.4(1000)	43.3(1100)	45.3(1150)	57.1(1450)	57.1(1450)	
Load length (nominal fork length)									
Load width	in(mm)	32(813)	36(914)	42(1067)	46(1168)	48(1219)	54(1372)	60(1524)	
	40(1016)	in(mm)	66.9(1700)	70.9(1800)	76.8(1950)	80.7(2050)	82.7(2100)	88.6(2250)	94.5(2400)
	44(1118)	in(mm)	68.7(1746)	72.7(1846)	78.6(1996)	82.5(2096)	84.5(2146)	90.4(2296)	96.3(2446)

①Add a minimum of 12in (300 mm) for maneuverability.

